



75 Watt, 180 – 450VDC Wide Input DC/DC Converters Series DV75Q2-300



Features

- 75 Watt Isolated Output
- Regulated Outputs
- 2 : 1 Wide Input Range 180 – 450 VDC
- Isolation I/O 3000Vac
- Fixed Switching Frequency
- Remote ON/OFF
- Shock & Vibration Meet MIL-STD-810F
- Safety Meet IEC/EN/UL62368-1 2nd (Reinforce Insulation)
- Quarter Brick Size Meet Industrial Standard 57,9 x 36,8 x 12,8 (mm)
- Efficiency to 90%
- Continuous Short Circuit Protection
- Protection OVT/OCP/OVP/UVLO
- Operating Case Temperature -40 to +105°C
- Low No Load Power Consumption
- Fire & Smoke Meet EN45545-2
- 3000m Operating Altitude

MODEL NUMBER	INPUT VOLTAGE [VDC]	OUTPUT VOLTAGE [VDC]	OUTPUT CURRENT [A] MAX.	INPUT CURRENT NO LOAD [mA]	INPUT CURRENT FULL LOAD [A]	EFF. [%] (Note 2)	CAP. LOAD Max. [µF]	CASE
DV75Q2-300S05	180 – 450	5	15	10	3,0	82	15000	Q
DV75Q2-300S12		12	6,25	10	2,8	88	6250	
DV75Q2-300S15		15	5	10	2,8	90	5000	
DV75Q2-300S24		24	3,12	10	2,8	90	3300	
DV75Q2-300S48		48	1,56	10	2,8	89	1000	

NOTE:

1. Nominal Input Voltage 300 VDC.
2. Measured at 300V_{in}
3. Example **DV75Q2-300S24N-C**
75Watt, Q: Quarter Brick, 2: Input: 2:1, 300: 180-450Vdc, S: Output Single 24Vdc, N: Negative Logic, -C: Clear Mounting Insert
4. All Specifications Typical At Nominal Line, Full Load, and 25°C Unless Otherwise Noted.
5. Ripple and Noise measured with an external MLCC 1000pF connected between –V_{in} to Case, and 10µF aluminum and 1µF ceramic capacitor across output for 48V_{out}, and with 10µF tantalum and 1µF ceramic capacitor for others

INPUT SPECIFICATIONS:

Input Voltage Range.....	300V.....	180-450Vdc
Input Surge Voltage.....	100ms max.....	500Vdc max.
Input Under Voltage Lockout	Turn-On Voltage Threshold	165V min / 175V max.
	Turn-Off Voltage Threshold	155V min. / 165V max.
Maximum Input Current.....	Vin=180V, Full Load, Vo 5V	520mA typ.
	Vin=180V, Full Load, Vo Others	477mA typ.
Inrush Current.....		0,1 A ² s max.
Input Reflected Ripple Current....	P-P thru 12uH inductor, 5Hz to 20MHz	30mA typ.
Input Filter		PI Type
Positive Logic Remote On/Off, Refer to -Vin pin.		
Logic Low (Module Off)	Von/off at Ion/off=1.0mA	0 to 1.2Vdc
Logic High (Module On)	Von/off at Ion/off=0.0uA, Pin open=On	3,5 to 75Vdc
Suffix "N" to the model number with negative logic Remote On/Off		
Logic Low (Module Off)	Von/off at Ion/off=0.0uA, Pin open=Off	3,5 to 75Vdc
Logic High (Module On)	Von/off at Ion/off=1.0mA	0 to 1.2Vdc
On/Off Current (for both remote on/off logic).....	Ion/off at Von/off=0V	1 mA max.
Leakage Current (both remote on/off logic).....	Logic High, Von/off=15V	30 uA max.
Off Converter Input Current	Shutdown input idle current	10 mA max.

OUTPUT SPECIFICATION:

Voltage Set Point Accuracy	Vin=36V, Full Load	±1,0% max.
Output Current Min.....		0 mA min.
Line Regulation.....	Vin High Line to Low Line, Full Load	±0,2% max.
Load Regulation	Full Load to No Load	±0,2% max.
Temperature Coefficient.....		±0,02%/°C max.
Ripple and Noise (5Hz to 20 MHz BW) (Note 5).....	5V	60mV RMS / 100mV pk-pk max.
	12V & 15V	60mV RMS / 150mV pk-pk max.
	24V	100mV RMS / 240mV pk-pk max.
	48V	200mV RMS / 480mV pk-pk max.
Over Current Protection	Hiccup Mode, Auto Recovery	110%-160%
Short Circuit Protection		Continuous, Auto Recovery
External Trim Adj. Range	Po ≤ max rated power, Io ≤ Io_max, Vo 5V	-20% min, +10% max.
	Po ≤ max rated power, Io ≤ Io_max, Vo Others	-20% min, +20% max.
Voltage Remote Sense	Po ≤ max power, Io ≤ Io_max % of nom. Vo 5V	+15% max.
	Po ≤ max power, Io ≤ Io_max % of nom. Vo Others	+20% max.
Over Voltage Protection (Limited Voltage, % Vo nom)	Vo 5V	112-130%
	Vo Others	122-130%
Output Voltage Current Transient: 75% to 100% Step Load Change (within 1% Vout nominal)		
Error Band		±5% max.
Recovery Time		250µ sec. max.
Output Voltage Rise Time	10%Vo_set to 90%Vo_set	30ms
Start up Time		30ms typ.

GENERAL SPECIFICATIONS:

Efficiency		See Table
Isolation Voltage (1 Minute)	Input/Output	3000VAC max. / 4200VDC max.
	Input/Case (Baseplate)	2500VAC max. / 3500 VDC max.
	Output/Case (Baseplate)	500VAC max. / 700 VDC max.
Isolation Resistance		100 MΩ min.
Isolation Capacitance	Input/Output	333pF typ.
	Input to Case (Base Plate)	None
	Output to Case (Base Plate)	4400pF typ.
Switching Frequency		300 KHz typ.
Operating Case Temperature		-40°C to +105°C
Storage Temperature		-55°C to +125°C
Over Temperature Shutdown.....	Temp. at Center Part of Base Plate	110°C typ.
Over Temperature Recovery	Temp. at Center Part of Base Plate	100°C typ.
MTBF 25°C (MIL-HDBK-217F, GB, Full Load) 5V/12V/15V/24V		850 Khours typ.
	48V	1050 Khours typ.
Humidity		95% RH max. Non condensing
Altitude		3000m Operating Altitude, 12000m Transport Altitude
Thermal Shock		MIL-STD-810F
Fire & Smoke		Meet EN45545-2
Safety.....		Meets IEC/ENUL62368-1 2nd (Reinforce Insulation)
EMI.....		Meets EN55032 & EN50155 Class A (with external filter)
ESD.....	EN61000-4-2 Level 3: Air ±8kV, Contact ±6kV	
Radiated immunity.....	EN61000-4-3 Level 3: 80-1000MHz, 20V/m	
Fast Transient.....	EN61000-4-4 Level 3: On power input port, ±2kV, external input capacitor required	
Surge	EN61000-4-5 Level 4: Line to earth, ±4kV, Line to line, ±2kV	
Conducted immunity.....	EN61000-4-6 Level 3: 0.15-80MHz, 10V	
Power Frequency Magnetic Field immunity	EN61000-4-8 50/60Hz, 3A/m (r.m.s.)	
Shock/Vibration		Meets MIL-STD-810F
Dimensions		2.28x1.45x0.50 inches (57.9x36.8x12.8 mm)
Potting Material.....		UL 94-V0
Case Material		Aluminum Baseplate with Plastic Case, UL 94-V0
Weight.....		61g typ.

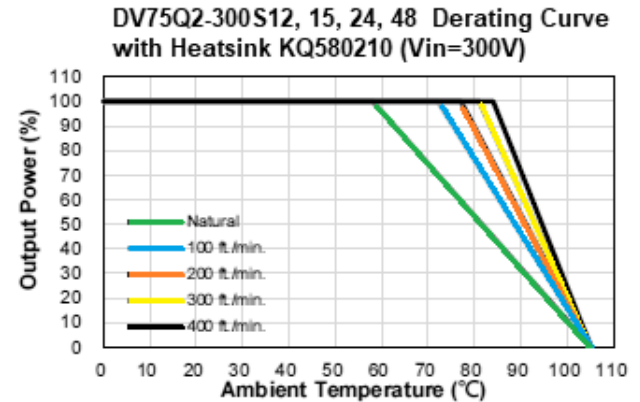
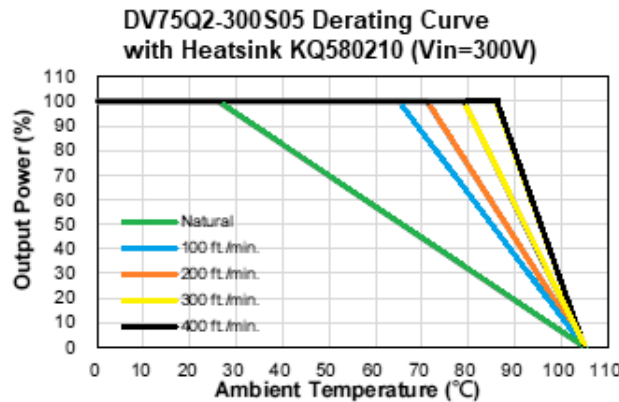
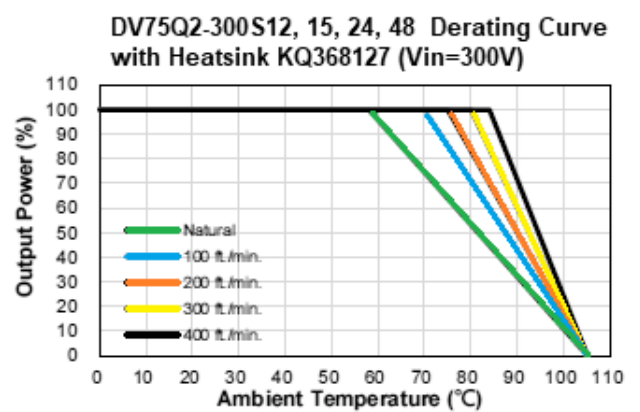
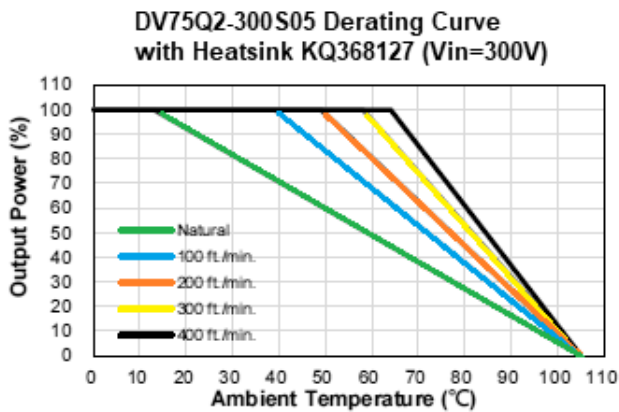
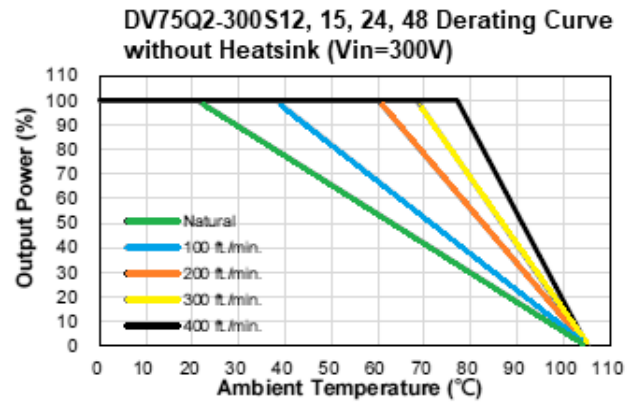
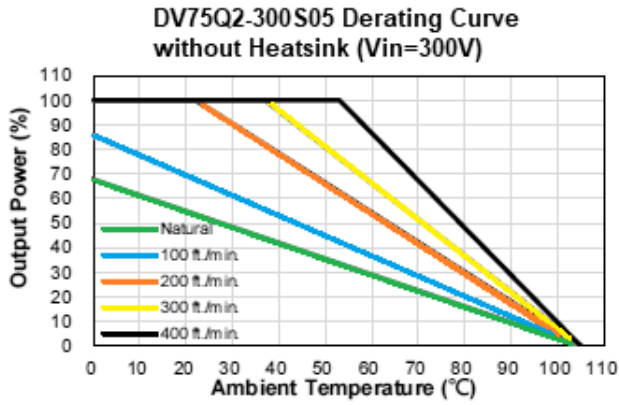

All Dimensions in Inches (mm)

Tolerance Inches x.xx±0.02 x.xxx±0.010
 Millimeters x.x±0.5 x.xx±0.25

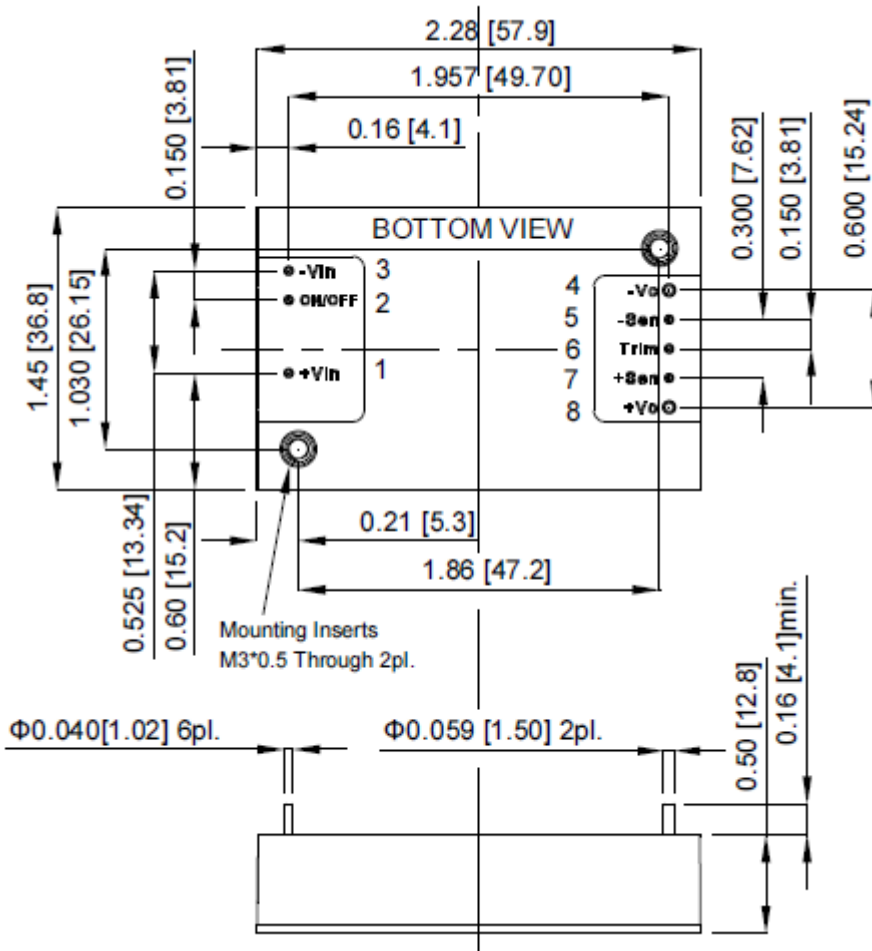

PIN CONNECTION	
Pin	Function
1	+V Input
2	On/Off
3	-V Input
4	-V Output
5	-Sense
6	Trim
7	+Sense
8	+V Output

CASE Q: HEAT SINK

Order No. 17.079.206
 Model No. KQ580210
 all dimensions in mm

Order No. 17.079.209
 Model No. KQ368127

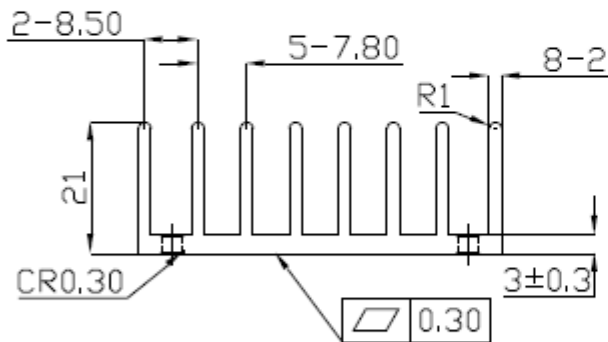
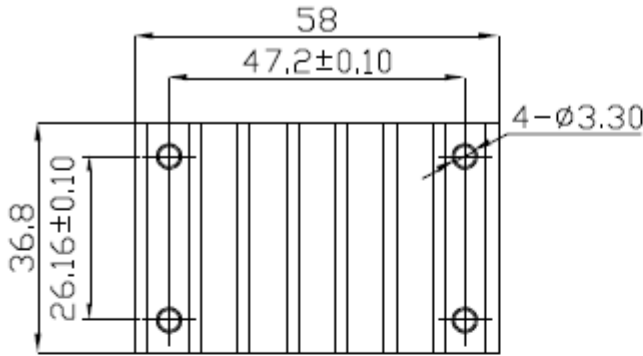

All Dimensions in mm
KQ580210
Heat Sink

- Rca: 4.78°C/W (typ.), At natural convection
- 2.44°C/W (typ.), At 100LFM
- 2.06°C/W (typ.), At 200LFM
- 1.76°C/W (typ.), At 300LFM
- 1.58°C/W (typ.), At 400LFM

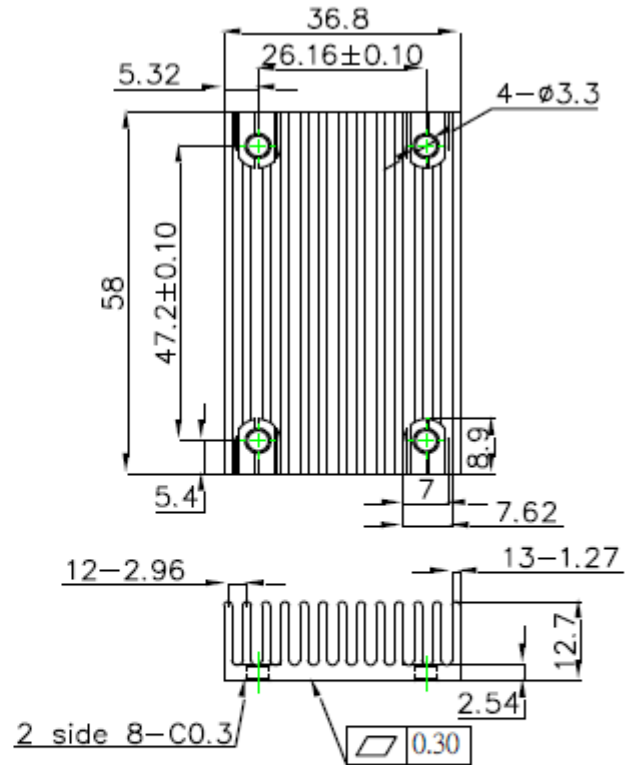

KQ368127
Heat Sink

- Rca: 5.61°C/W (typ.), At natural convection
- 4.01°C/W (typ.), At 100LFM
- 3.39°C/W (typ.), At 200LFM
- 2.86°C/W (typ.), At 300LFM
- 2.49°C/W (typ.), At 400LFM

Heat Sink Assembly
 example

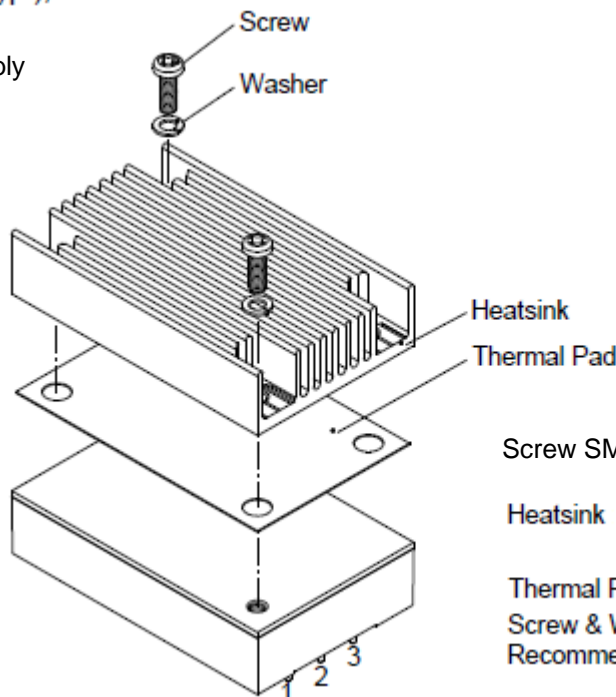

Screw SMP+SW M3x8L

Heatsink KQ580210
 KQ368127

Thermal Pad SZ35.8x56.9x0.25mm
 Screw & Washer
 Recommended torque 3 Kgf-cm